

## The Clipper Titan 44 Cleaner

An eight screen cleaner that utilizes eight decks. In the top shoe each of the 4 screen decks uses 4-26" screen sections with a split-scalp flow with the screens set at a 8 degree pitch . In the bottom shoe each of the 4 screen decks uses 4-26" screen sections with a 4-way split-sift flow with the screens set at a 10 degree pitch. A total of 312 Square feet of screen area.

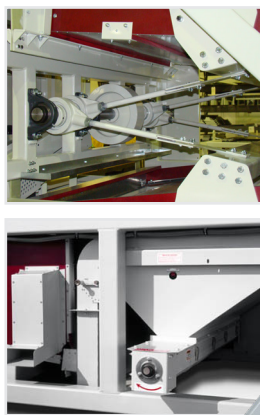

### STANDARD FEATURES:

- 4" square tubing frame that is 1/4" (6.35mm) thick.
- Exclusive electronic variable speed 1/2" throw on eccentric drive of cleaning shoes for smooth seed flow and maximum seed separation.
- Reverse incline back fan unit to develop up to 11,000 CFM @ 5" SP. Drive setup can easily be changed to match air and electrical requirements.
- Electronic variable speed vibratory inlet feed hopper with adjustable internal gate for uniform seed flow thru air column and onto screens.
- New style heavy duty screen cleaning ball trays so that screens can be changed without removing ball trays.
- 2 calibrated air gate controls that work in combination with back adjustable doors for precise air separation settings.
- Replaceable metal screenways and rubber screen seals for ease of future repair.
- New style shoe hangers and drive connectors for smooth counter balanced operation.
- Air lock discharge trash augers with bottom access door for ease of cleanout.

### CAPACITIES:

Small Seed	325-650 BPH	(4.4-8.2 MTH)
Medium Seed	650-1300 BPH	(8.2-16.5 MTH)
Large Seed & Wheat	1300-2000 BPH	(34-54.5 MTH)
Market Cleaning	2500-3500 BPH	(68-94 MTH)

**Note:** Capacities may vary depending on seed condition, moisture content, seed varieties, types and volumes of contaminants to be separated and the percentage of foreign material accepted in the final product.

### OPTIONS:

- Over 150 different standard screen sizes available with additional screen sizes available upon request.
- Bottom blast fan for specialized or extreme air separation requirements.
- Grease line package to grease machine from central location.
- Various motor drive packages of 50 or 60 Hertz, TEFC or Ex-Proof
- Side mounted control panel to control electronic variable speeds from one location.
- Calibrated hopper gate control extended down to side of machine.

### TECHNICAL SPECIFICATIONS:

Extreme Height	161.5 inches / 410 cm
with Bottom Fan	178.5 inches / 453 cm
Extreme Width	91.3 inches / 232 cm
Width on Floor	71.5 inches / 182 cm
Length on Floor	197.2 inches / 501 cm

### ELECTRICAL REQUIREMENTS:

Main Fan Motor	15 H.P. / 11.25 Kw
Eccentric Motor	5 H.P. / 3.75 Kw
Vibratory Feeder Motor	½ H.P. / .375 Kw

### AIR OUTPUT:

8,400 to 11,000 CFM



SEAN MCGIVERN  
NORTH VALLEY AG & MILL

PH: (519) 374-9300 or (902) 393-9097

EMAIL: [sean@northvalleyagme.com](mailto:sean@northvalleyagme.com)  
WEB: [www.NorthValleyAgMe.com](http://www.NorthValleyAgMe.com)



### DIMENSIONS: (INCHES)

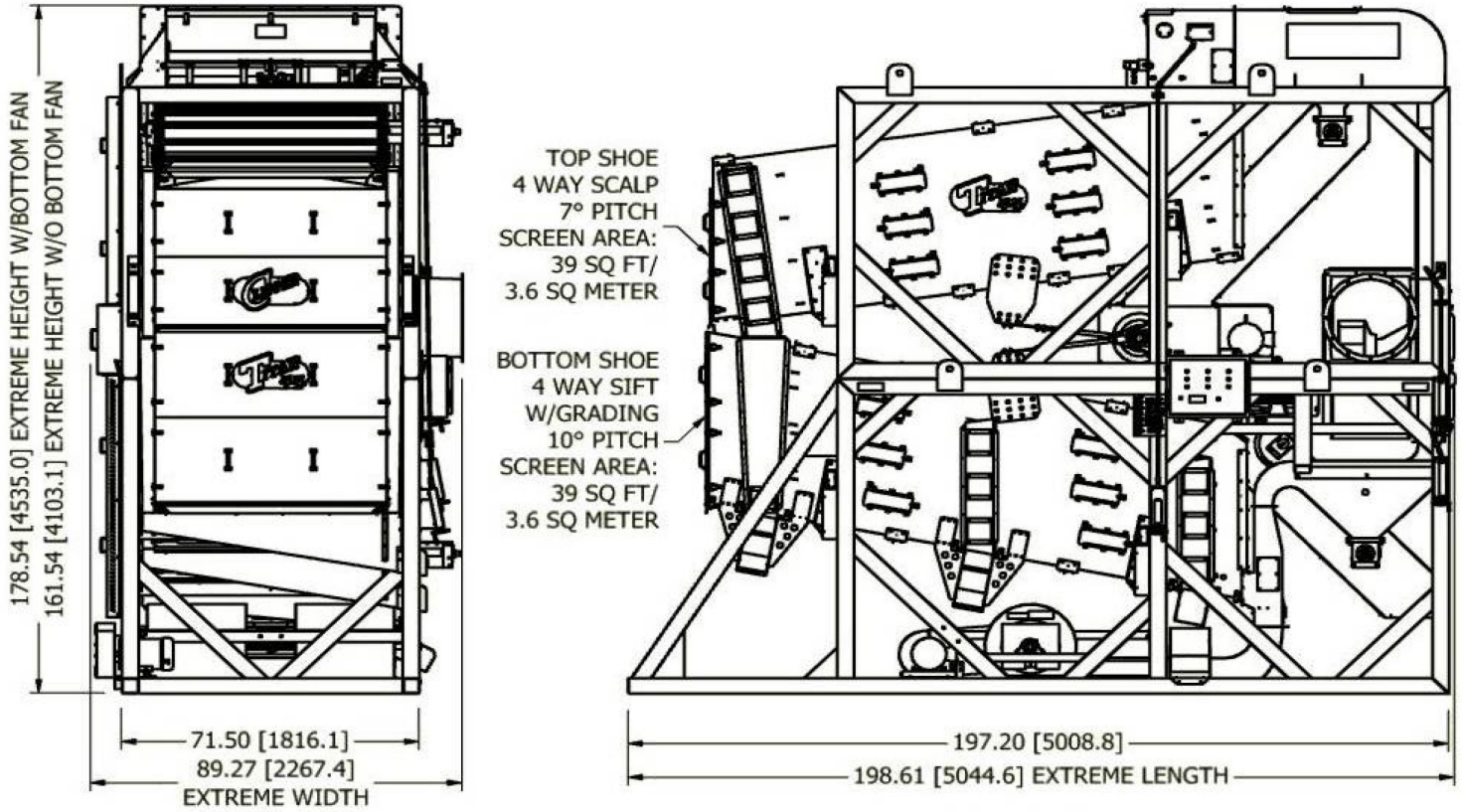

### BOTTOM VIEW (OUTLET AND MOUNTING DETAILS):

