

Experience Unmatched Power: MILL-R200 Pellet Machine

Part of CME's Millennium Series, the Mill- R200 Pellet Machine stands as a robust, full-sized production unit boasting one of the highest horsepower-to-surface area ratios in its class.

Capable of producing 3,000 to 24,000 lbs of pellets per hour, its output varies with the raw material. This versatile unit is designed for applications ranging from animal feed, and plastics, to fertilizer, and even demanding tasks like wood pellet production. With a rating of up to 200 HP, it's your ultimate pellet mill solution.

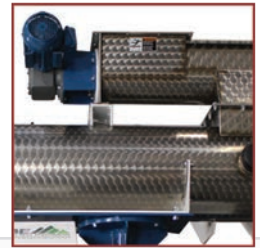

STANDARD FEATURES:

- Industrial 200 HP, TEFC main drive motor
- New dies available: 1/8" to 3/4"
- Custom die sizes available upon request
- Safety guards on all pulleys
- Quick-change shear pin assembly
- Easy-adjust knife post to change pellet length
- Simple and reliable belt drive system
- Stainless door with safety interlock
- Super duty 1" thick steel base plate
- Timken internal bearings
- Swivel stand mounting on feeder / conditioner
- Powder coated with FDA approved materials
- Forklift slots for easy mobility
- Easy-slide motor adjustment
- Operator's manual included
- Designed, built, & supported in the USA
- CME's Signature 1-Year Manufacturer's Warranty

OPTIONS:

- Change Parts Required: New Die
- Change Parts Required: New Roller Assembly Set
- Stainless Conditioner
- Stainless Variable Pitch Feeder
- Stainless Heavy Duty Force Feeder
- Leg Extensions 24"
- Magnet (requires purchase of a Force Feeder)
- Food Grade Grease
- Auto Lubrication System
- Isolation Pad Set
- Safety Control Panel

SPECIFICATIONS:

Motor: 75-200 HP

Capacity / HR:

3,000-24,000 LBS

Die Inner Dia: 16.5" Ring

Dimensions (IN):

80" L x 90" W x 89" H

Weight:

10,000-12,000 LBS



DIMENSIONS:

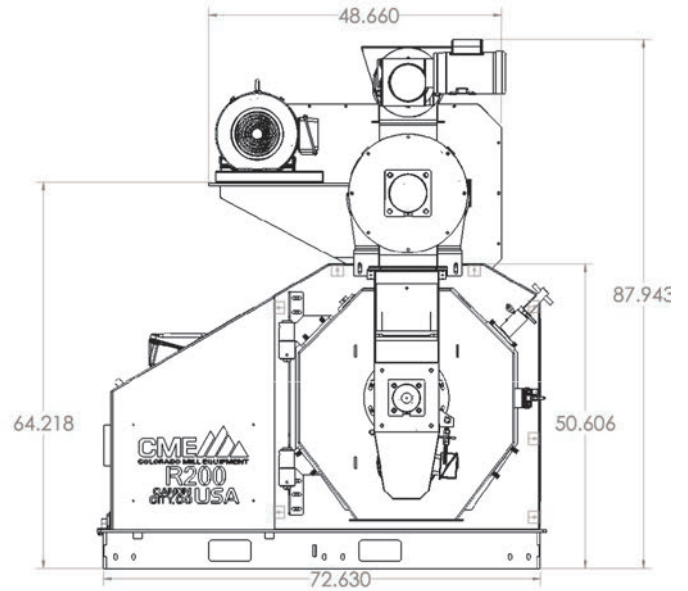
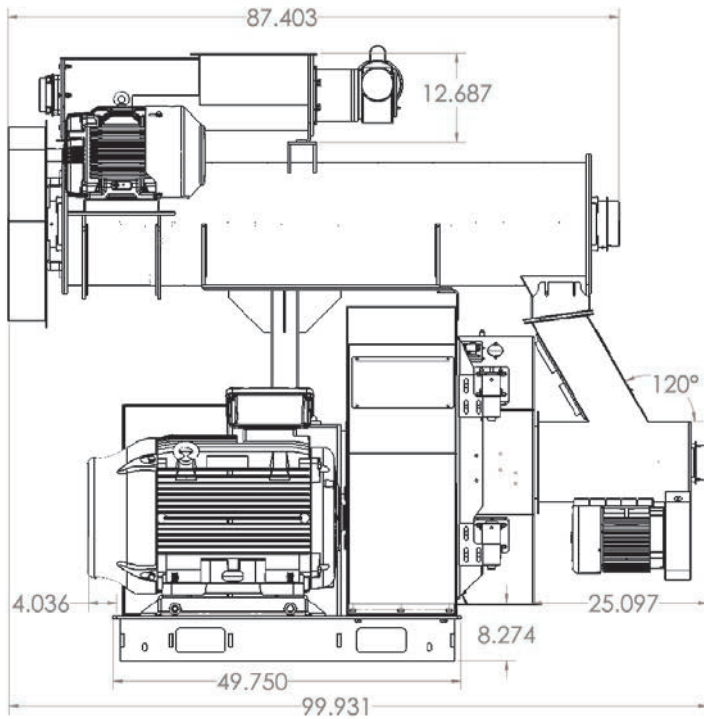
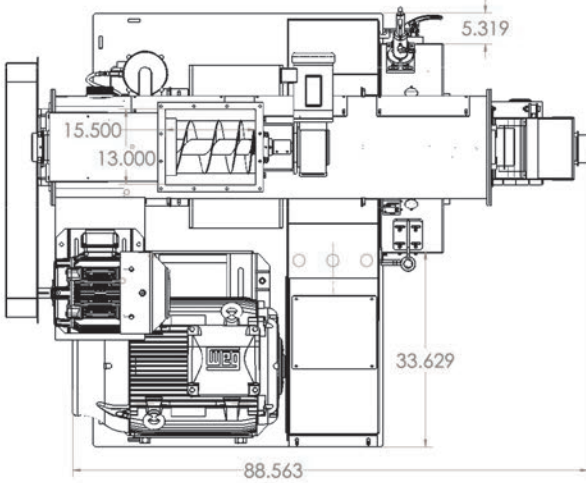

Alfalfa

Corn

Recycling & Plastics

Hops

Wood

