

The Prelude 826 offers two counter balanced shoe assemblies consisting of a Scalp-Scalp-Sift flow or a Scalp, Split-Sift Flow. All screens are 54" wide. The top scalping screen deck is two screen sections in length while the other two screen decks are three screen sections each in length. All screen sections are 54" x 26" sections. The Prelude 826 utilizes doors that hold in screens so no screen hooks are required, Ball Tray Cleaning Technology, Variable Screen Configurations and Pre-Suction and After-Suction Aspiration with Adjustable Air Controls.



STANDARD FEATURES:

- 3" square tubing frame that is 1/4" thick
- Reverse incline back fan unit develops 5,700 CFM. Drive setup can easily be changed to match air and electrical requirements.
- Air lock discharge trash spout
- Fixed speed vibratory inlet feed hopper with adjustable internal gate for uniform seed flow thru air column and onto screens 2 air gate controls for precise settings and air separation.
- New style screen cleaning ball trays so that screens can be changed without removing ball trays
- Front doors hold in screens so no screen hooks required
- Replaceable metal screenways and rubber screen seals for ease of future repair
- New style shoe hangers and drive connectors along with shoe counter balance for smooth operation

TECHNICAL SPECIFICATIONS:

Extreme Height	112.5 inches / 285.7 cm
with Bottom Fan	85.4 inches / 216.8 cm
Extreme Width	126.11 inches / 320.3 cm
Width on Floor	69.5 inches / 176.5 cm
Length on Floor	88.75 inches / 225.1 cm

AIR OUTPUT:

6,000 CFM

ELECTRICAL REQUIREMENTS:

Main Fan Motor	10 H.P./ 7.5 Kw
Eccentric Motor	2 H.P. / 1.5 Kw
Vibratory Feeder Motor	1/2 H.P./ .35 Kw

OPTIONS:

- Over 150 different screen sizes available.
- Bottom blast fan integrated into standard frame with no change in machine height.
- Electronic variable speed vibratory inlet feed hopper.
- Grease line package to grease machine from central location.
- Side mounted control panel to control electronic variable speeds from one location.
- Various motor drive packages of 50 or 60 hertz, single or three phase, TEFC or Ex-Proof
- 24", 36" or 48" stands available to elevate cleaner if needed.
- Clean seed conveyors from 5 to 15 feet to convey seed away from cleaner.

CAPACITIES:

Small Seed	150 Bu./Hr. (1.95 MT/Hr)
Medium Seed	250 Bu./Hr. (4.4 MT/Hr)
Large Seed & Wheat	350 Bu./Hr. (9.4 MT/Hr)
Market Cleaning	1200 Bu./Hr. (32.6 MT/Hr.)

BPH = bushels per hour
MTH = metric tons per hour

* Capacities may vary depending on seed condition, moisture content, seed varieties, types and volumes of contaminants to be separated and the percentage of foreign materials acceptable in the final product.



SEAN MCGIVERN
NORTH VALLEY AG & MILL

PH: (519) 374-9300 or (902) 393-9097

EMAIL: sean@northvalleyagme.com
WEB: www.NorthValleyAgMe.com



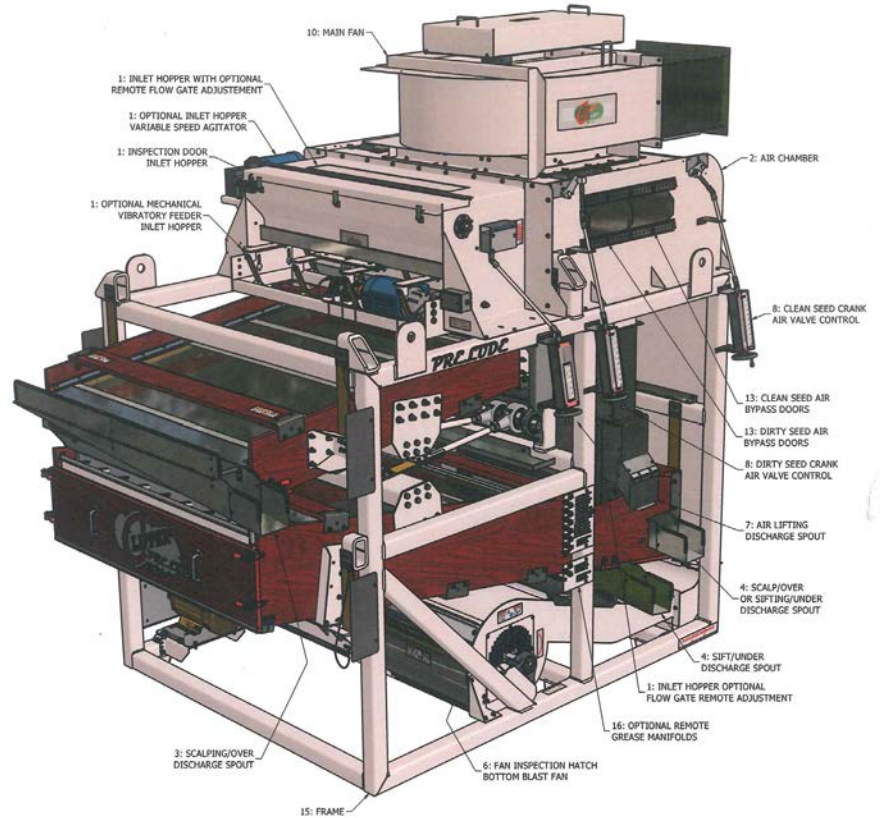

DIMENSIONS: (INCHES)

