

The Prelude 526 offers a single-shoe assembly consisting of a Scalp-Scalp-Sift flow or a Scalp, Split-Sift Flow. All screens are 54" wide. The top scalping screen deck is 34" in length while the other two screen decks are 60 inches in length. All screen sections are 54" x 26" sections. The Prelude utilizes Ball Tray Cleaning Technology, Variable Screen Configurations and Pre-Suction and After-Suction Aspiration with Adjustable Air Controls.



STANDARD FEATURES:

- 3" square tubing frame that is 1/4" thick
- Reverse incline back fan unit develops 5,700 CFM. Drive setup can easily be changed to match air and electrical requirements.
- Air lock discharge trash spout
- Fixed speed vibratory inlet feed hopper with adjustable internal gate for uniform seed flow thru air column and onto screens
- 2 air gate controls for precise settings and air separation.
- New style screen cleaning ball trays so that screens can be changed without removing ball trays
- Replaceable metal screenways and rubber screen seals for ease of future repair
- New style shoe hangers and drive connectors along with a shoe counter balance for smooth counter balanced operation

TECHNICAL SPECIFICATIONS:

| | |
|-----------------|----------------------|
| Extreme Height | 91 inches / 232 cm |
| with Bottom Fan | 78.5 inches / 200 cm |
| Extreme Width | 91.5 inches / 233 cm |
| Width on Floor | 69.5 inches / 177 cm |
| Length on Floor | 73.5 inches / 187 cm |

AIR OUTPUT:

6,000 CFM

ELECTRICAL REQUIREMENTS:

| | |
|------------------------|-----------------|
| Main Fan Motor | 10 H.P./ 7.5 Kw |
| Eccentric Motor | 2 H.P. / 1.5 Kw |
| Vibratory Feeder Motor | Optional |

OPTIONS:

- Over 150 different screen sizes available.
- Electronic variable speed vibratory inlet feed hopper.
- Grease line package to grease machine from central location.
- Side mounted control panel to control electronic variable speeds from one location.
- Various motor drive packages of 50 or 60 hertz, single or three phase, TEFC or Ex-Proof
- 24", 36" or 48" stands available to elevate cleaner if needed.
- Clean seed conveyors from 5 to 15 feet to convey seed away from cleaner.

CAPACITIES:

| | |
|--------------------|-------------------------|
| Small Seed | 100 Bu./Hr. (1.3 MT/Hr) |
| Medium Seed | 175 Bu./Hr. (3.1 MT/Hr) |
| Large Seed & Wheat | 200 Bu./Hr. (5.4 MT/Hr) |

BPH = bushels per hour MTH = metric tons per hour

* Capacities may vary depending on seed condition, moisture content, seed varieties, types and volumes of contaminants to be separated and the percentage of foreign materials acceptable in the final product.



SEAN MCGIVERN
NORTH VALLEY AG & MILL

PH: (519) 374-9300 or (902) 393-9097

EMAIL: sean@northvalleyagme.com

WEB: www.NorthValleyAgMe.com

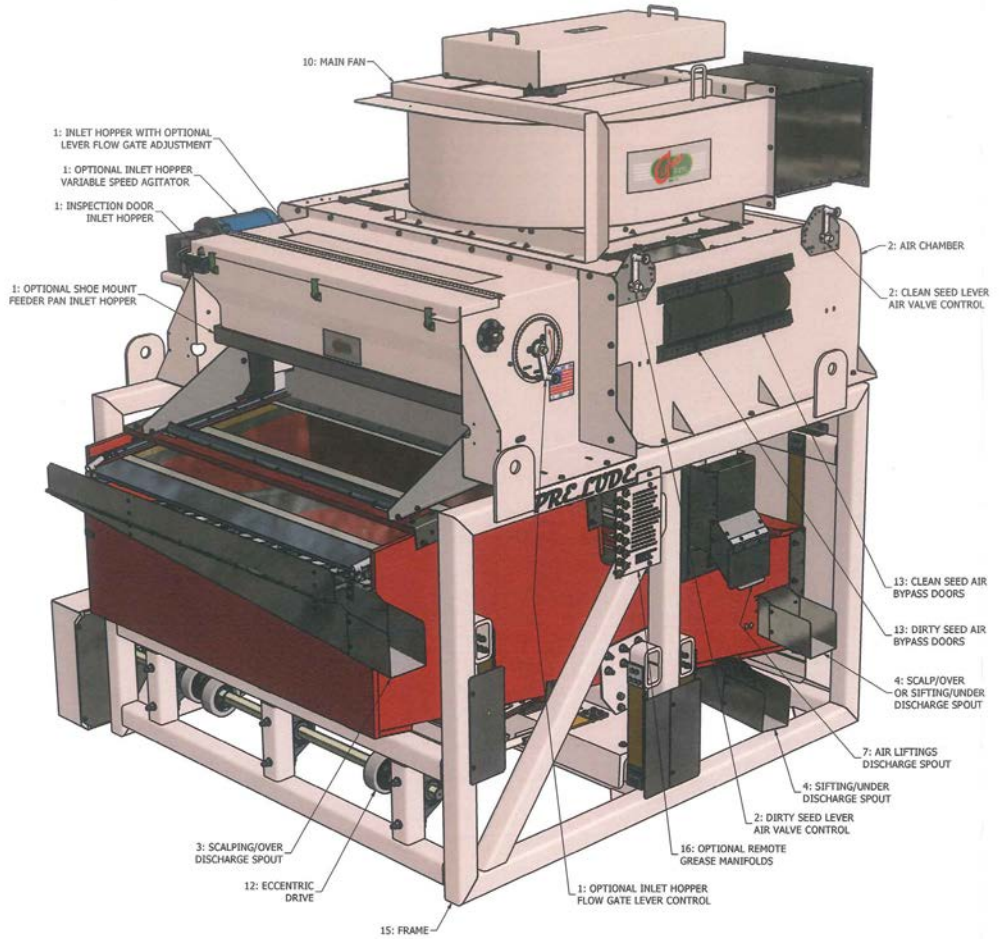

DIMENSIONS: (INCHES)

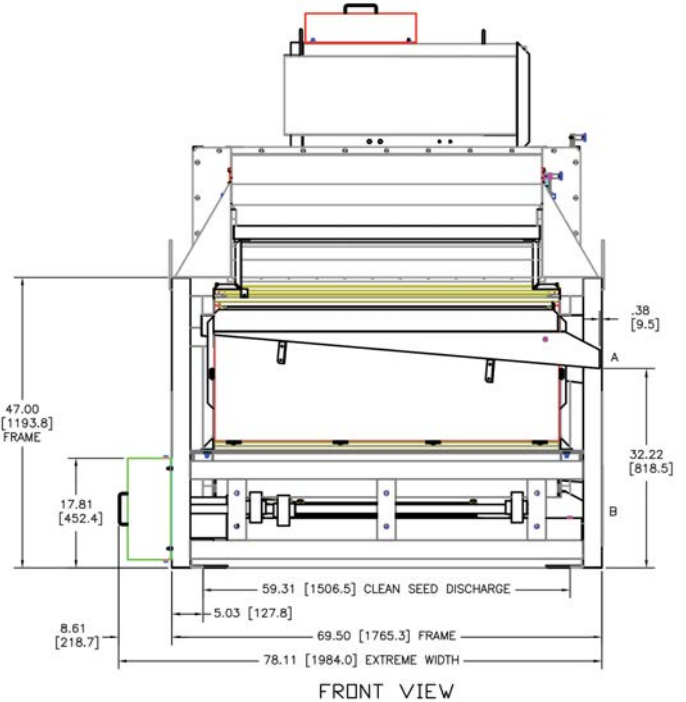
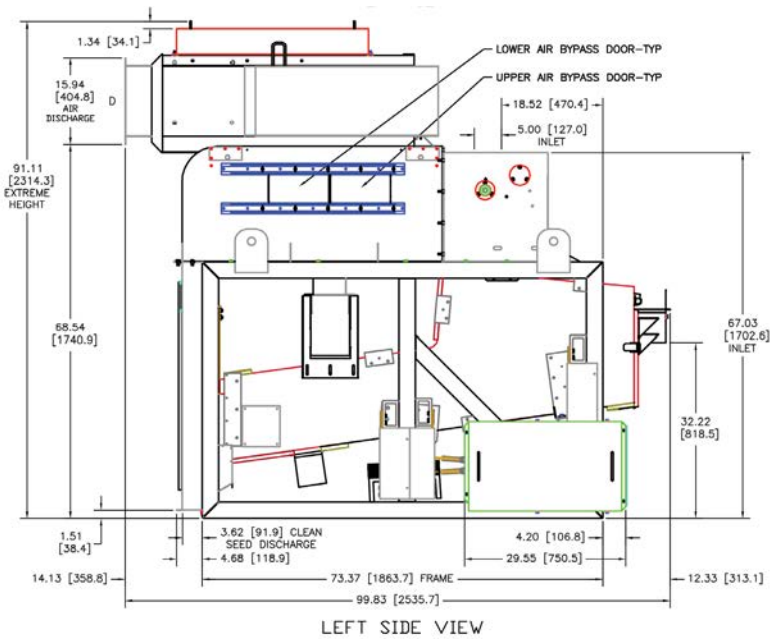

SEAN MCGIVERN
NORTH VALLEY AG & MILL

EMAIL: sean@northvalleyagme.com
WEB: www.NorthValleyAgMe.com

PH: (519) 374-9300 or (902) 393-9097

