

The Kongskilde batch weighers operate on a continuous batch weighing principle, in which the material flows constantly through the weigher at a given capacity.

Weighing is based on establishing a balance between the batch of the material and the weigher's fixed weight. This ensures optimum accuracy, irrespective of the material being weighed.

The robust but simple construction of the weighers ensures their reliable operation and makes the various models well suited to many agricultural and industrial applications.



KA-10



KA-25



APPLICATIONS:

The weighers may be used to record total throughput or to cut off the material flow once the required weight has been achieved.

RANGE OF MATERIALS:

The weighers can be used for the weighing of cereals and other granular materials up to a particle size of 15 mm. They can also be used to weigh coarse ground materials, but are not suitable for fine meal or similar materials which bridge easily.

Their design enables them to be incorporated into conveying systems: to record material weight entering and leaving storage, to control ingredient weight for milling, and finished mix weights for on-farm distribution.

SELECTING THE CORRECT WEIGHER

The weigher should have, at least, a capacity equal to other equipment involved in the installation.

CONTROL OF MATERIAL FLOW

Weighers fitted with pre-set electrical counters can control the starting and stopping of conveying systems and Capacity t/h (dry barley) Volume per compartment, litres Net weight, kg Accuracy deviation (subject to correct adjustment and operation) 6-12 8 26 30 +/-1% 20-30 40-60 40-60 70-125 15 25 27 40 68 130 120 225

52 75 85 142 +/-1% +/-1% +/-0,5% +/-0,5% the opening and closing of electrically or pneumatically operated shutters.

Such controls are possible using either of the control units, types DE and DRE, in conjunction with the KA 10 and KA 25.

TWIN-COMPARTMENT WEIGHERS The smallest models are suitable for mixing and feeding installations. The KA 10 can be fitted with an inlet control shutter (see accessories).

WEIGHER TYPE	TWIN COMPARTMENT WEIGHERS	
	KA-10	KA-25
Contents per comp. std. kg.	10	25
Contents per comp. min/max. kg.	6-12	20-30
Capacity th (dry barley)	8	15
Volume per compartment litres	26	68
Net Weight, kg	30	52
Accuracy deviation (subject to correct adjustment and operation)	+/- 1%	+/- 1%

EXAMPLE OF PRACTICAL APPLICATIONS

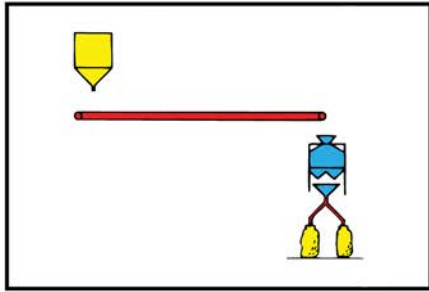

Checking weighing prior to bagging.

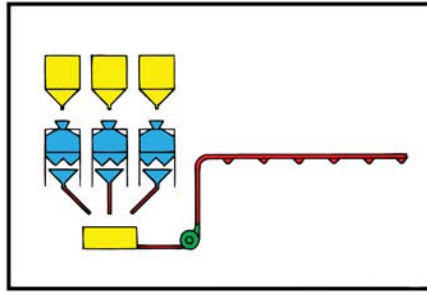

Blending ingredients for feed systems.

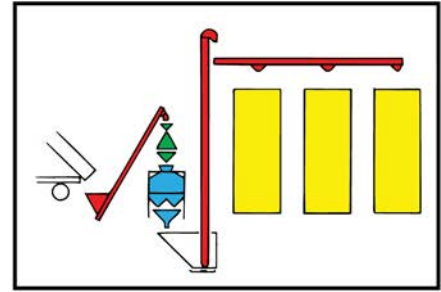

Checking weighing prior to bulk storage.

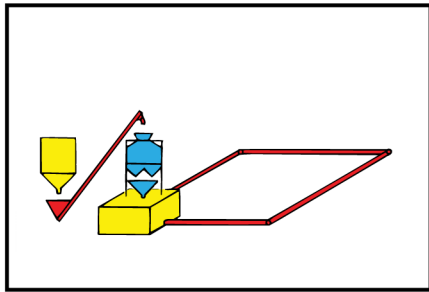

Monitoring feed consumption and controlling feed intervals/ consumption.

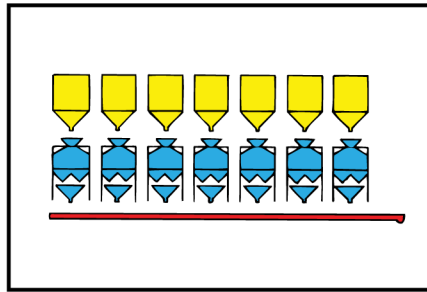

Blending of granular materials in industry.

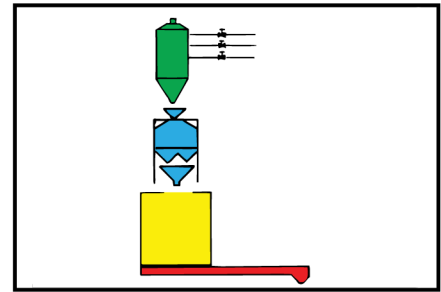

Controlling colour and material composition in plastic industry.

DIMENSIONS:

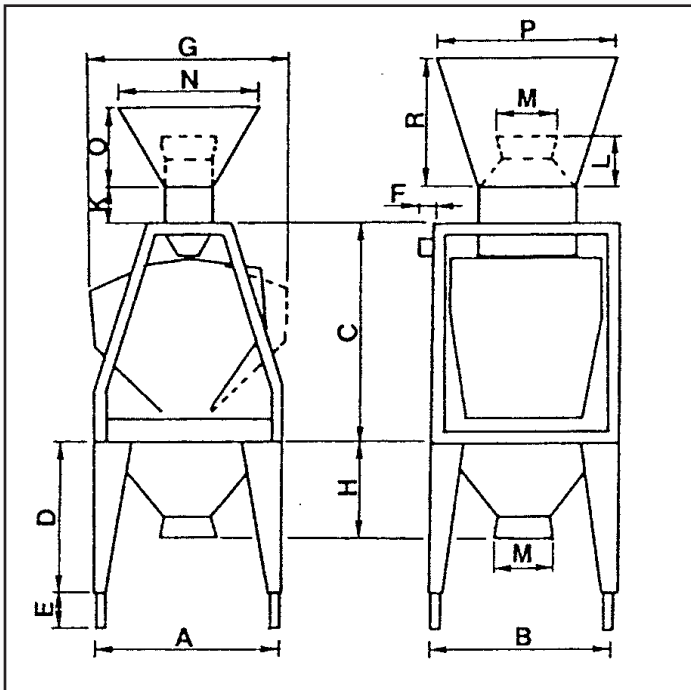

WEIGHER DIMENSION	KA-10	KA-25
A	500	660
B	500	660
C	585	730
D	400	600
E	0-300	0-400
F	40	40
G	550	720
H	250	350
K	100	100
L	125	125
M	OK160	OK160
N	400	400
O	200	200
P	480	480
R	335	335



**ELECTRONIC
COUNTER**

**BATTERY
POWERED
COUNTER**

**MECHANICAL
COUNTER**

ACCESSORIES

All weighers can be supplied with inlet hoppers (open type), inlet transitions for OK connection, outlet hoppers (square flange or for OK connection), and height adjustable leg sets. A flow control baffle, fitted as the inlet, is available for all type KA weighers.

COUNTERS

As standard, the weighers are fitted with robust 7 digit mechanical counters. As accessories, a battery powered counter together with a microswitch can be supplied. This counter is complete with 6 m of cable. When fitted with a microswitch, all weighers in the range can be linked to electronic counters, with or without batching facility, as well as other forms of control.

PULSE GENERATORS

These are generally microswitches, but pulse sensors can be fitted.

CHECK WEIGHING

All weighers should be checked for accuracy on a regular basis. In twin compartment weighers, the discharge has to be check-weighed. A check-weigh tester is available for the KA 10 model. For model KA 25 allowance should be made, when installing, for easy access to the outlet for collection of the discharge.

DUST ENCLOSURE

Dust covers are available for all models. The covers are of a modular design which facilitates the incorporation of dust extractors etc.

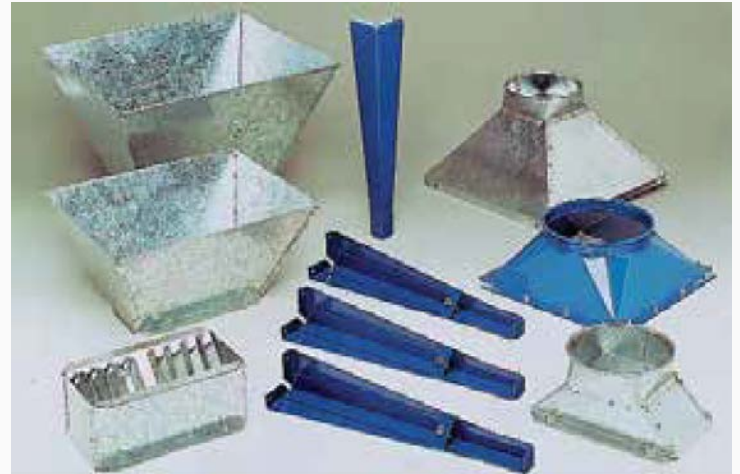

PROGRAMMABLE BATCH COUNTERS

Models KA 10 and KA 25 can be supplied with mechanical programmable batch counters. The programmable batch counters are set by a dial. The dial is set on the wanted quantity to be weighed.

Type D and DR for control of the inlet gate weigher's can be used for weigher type KA 10. Type De and DRE for electrical control of the feeding conveyor can be used for weighers type KA 10 and KA 25. Type D and DE can be set to repeat quantities delivered.

DRE DEVICE

DE DEVICE

