

Improve the Quality and Presentation of Edible Beans and Soybeans

- Available from 1 to 6 Box Configurations for Various Throughput Volumes
- Independent Motors for the Fan, Eccentric & Polishing Box Paddles
- Bean Matrix/Polishing Eccentric Screening and Return with Gentle Handling
- Vibratory Feed System on 3 through 6 Box Units Standard
- Easy access to polishing boxes and screens for clean-out and screen changes
- Heavy Duty Eccentric Assembly, all components are CNC Machined
- TEFC, NEMA Premium Efficient Motors; X-Proof Available Precision Fan Damper Controls

OTHER OPTIONS:

- 50 Hz Motors
- Collection/Discharge Spouting Packages
- SUB-Frames
- Fan Transitions & "Wye" Pants
- Tailored to accept Competitor Screens
- EP-1 or 2: Discharge Aspiration with or without fan
- Customized Machine Floor Plan



Quality Seed And Grain Equipment

QSAGE MODEL	HP REQUIREMENTS					CAPACITY BPH BEANS
	ECCENTRIC	FAN	FEED	BOXES	BUCKET ELEVATOR	
EBP - 1	1	N/A	N/A	1.5	0.5	50 - 100
EBP - 2	1.5	N/A	N/A	(2) @ 1.5	0.5	100 - 200
EBP - 3	2	5	1	3	0.75	150 - 300
EBP - 4	3	5 / 7.5	1	5	0.75	200 - 400
EBP - 5	3	5 / 7.5	1	5	0.75	250 - 500
EBP - 6	3	10 / 75	1	(2) @ 3	0.75	300 - 600

SUGGESTED POLISHING MEDIA :
 • SIZED CORN COB GRIT • DRY SAWDUST, CORN MEAL, ETC.,
 MAY BE EXPERIMENTED WITH

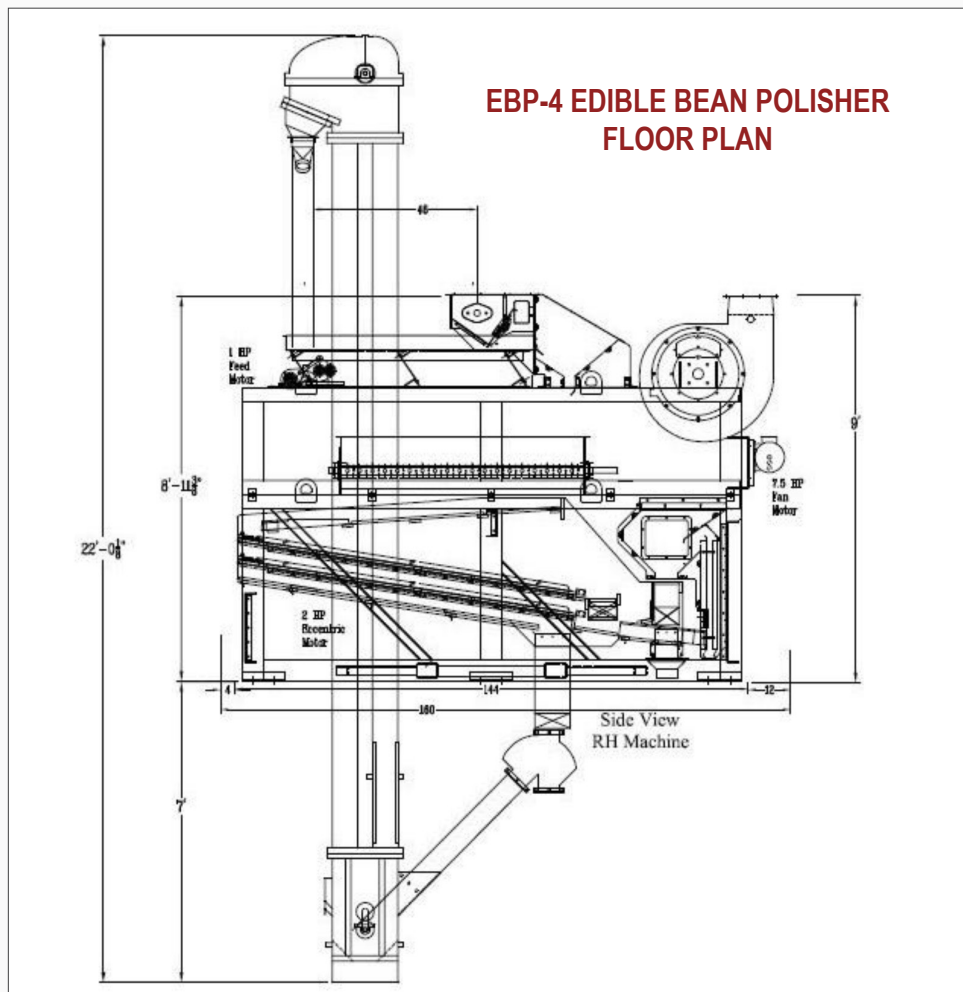

Polishing Media Mixes
Water / Cob Grit Mixture
Vinegar / Water / Cob Grit Mixture
Veg Oil / Vinegar / Water / Cob Grit
Polishing Notes
General dirt/dust removal
General dirt/dust and stain removal
General dirt/dust and stain removal + sheen