

Pegasus Gravity Tables

GRAVITY TABLES

Pegasus Gravity Tables feature a unique deck configuration capable of maximum capacity and excellent separation accuracy. Low CFM & horsepower requirements along with easy adjustments make the Pegasus Gravity Separators the one to own.

Available in 5 different sizes to suit your capacity needs.



The Pegasus models begin with the PG-14 with a capacity up to 210 BPH, then the PG-20, PG-27, PG-33 and the largest model which achieves capacities up to 600 BPH with only 40 square feet of deck area; the PG-40.

More efficient deck usage translates into reduced air requirements, horsepower and floor space. Typical gravity table capacities on wheat vary from 5-10 bushels per square foot of deck area. The Pegasus configuration results in capacities of 15-17 bushels per square foot of deck area, resulting in a quicker return on your investment.

There is a single fan to pressurize the entire Gravity Table deck surface. High efficiency backward inclined airfoil fan with an easily adjustable multi-vane inlet provides quiet efficient air volumes. The unit can be equipped as a negative system. Reduced horsepower translates to substantial energy savings during the life of the equipment. Low noise levels for a quieter plant environment. The 87 dBA @ 12000 CFM screen means no wasted air, low air requirements that result in a smaller dust collection system.

FEATURES AND BENEFITS

- Five Popular Models Available
- Outstanding Accuracy of Separation
- Very Easy to Operate
- Modern Design and Construction
- Most Energy Efficient
- Lowest Loss of Good Product in the Culls
- Heavy Duty Construction with Quality Components

OPTIONS

- Half or Full Dust Hood
- Middling Return Conveyor
- Split Middling Hopper
- Urethane Coated Overcover

GRAVITY TABLES

CAPACITY CHART

PEGASUS MODEL	CORN, BEANS	WHEAT, BARLEY	CANOLA, FLAX	ALFALFA, CLOVER
PG14A	125-140 bph	180-210 bph	70-85 bph	1100-1500lbs/hr
PG20A	175-200 bph	260-300 bph	100-120 bph	1650-220 lbs/hr
PG27A	275-340 bph	380-410 bph	160-200 bph	2500-3200 lbs/h
PG33A	335-415 bph	465-500 bph	195-245 bph	3000-3900 lbs/hr
PG40A	400-480 bph	550-600 bph	240-300 bph	3600-4800 lbs/hr

SPECIFICATIONS

MODEL	DECK AREA	MAXIMUM CFM	MOTOR REQUIREMENTS	OVERALL LENGTH	OVERALL WIDTH	OVERALL HEIGHT	SHIPPING WEIGHT
PG14A	14 ft ²	6,500	5 hp fan 1 hp eccentric	104"	73"	91"	2,420 lbs
PG20A	20 ft ²	8,800	7.5 hp fan 1 hp eccentric	111"	76"	65"	2,920 lbs
PG27A	27 ft ²	12,000	10 hp fan 1.5 hp eccentric	130"	92"	112"	4,450 lbs
PG33A	33 ft ²	14,850	15 hp fan 2 hp eccentric	137"	82"	115"	5,300 lbs
PG40A	40 ft ²	18,800	15 hp fan 2 hp eccentric	155"	96"	112"	6080 lbs

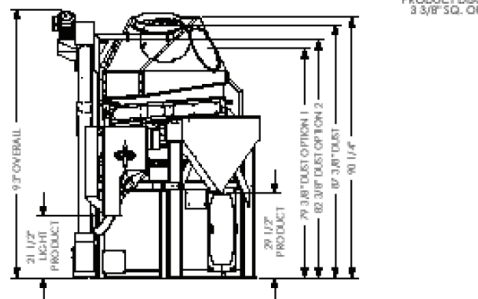
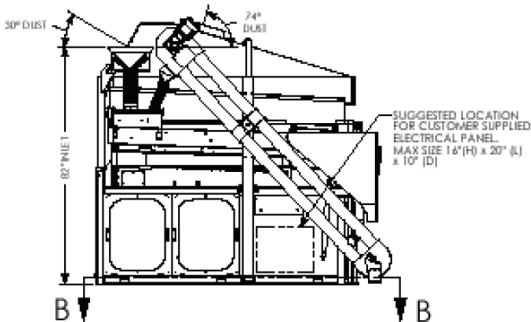
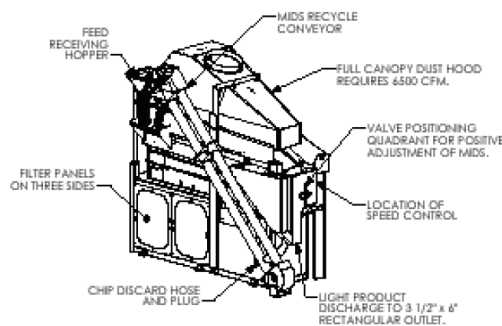
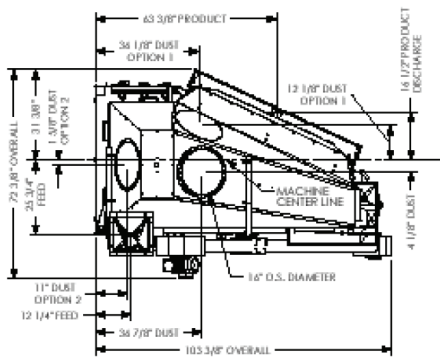

Dimensions for Model PG14A

GRAVITY TABLES