

TE100 Electronic Bagging Scales

Magnum Systems Model TE-100 includes more features than most large scales. The operator simply sets the weight and hangs the bag. The unit clamps the bag in place, fills, checks the weight, and drops the bag.

STANDARD FEATURES:

- Bulk and dribble fill cycle
- Bag in place switch prevents material spills
- Self-correcting weight feature
- T4000 weigh controller

MATERIALS TYPICALLY HANDLED ARE DRY, GRANULAR, FREE FLOWING PRODUCTS SUCH AS:

- Certified seed
- Pelleted feed
- Soybeans
- Lentils
- Fertilizer

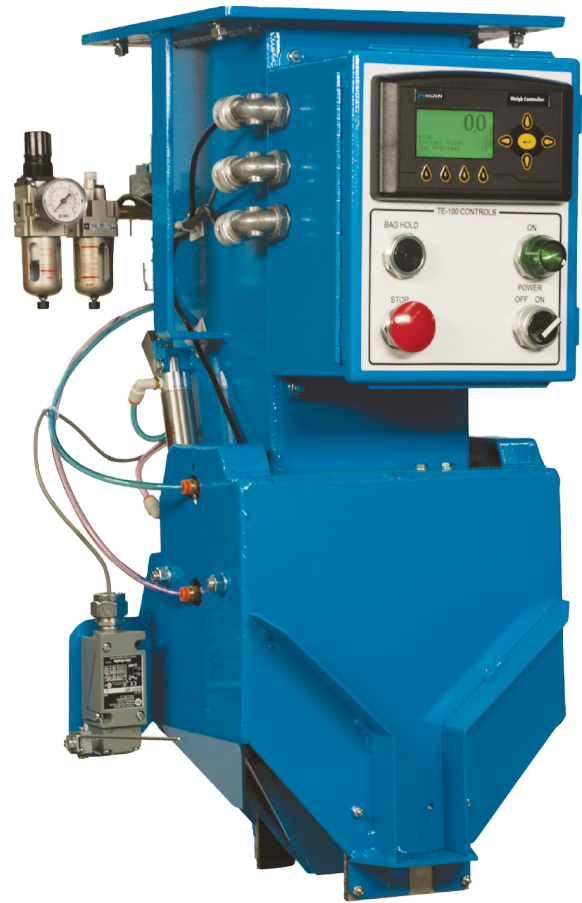

**INNOVATIVE COMPACT
ELECTRONIC BAGGING
SCALE WITH
SELF-CORRECTING
PRECISION**

SPECIFICATIONS:

Speed	Up to 14 BPM
Accuracy	+ 0.2 lbs
Weight Range	20 to 125 lb (9 kg to 56 kg) (Weight range is dependent on product's bulk density. Free product testing recommended.*)
Construction	Carbon Steel
Electrical Requirements	110 Volt, single phase
Air Requirements	90 PSI (6.21 BAR), 5 SCFM
Weight Readout	Backlit Digital Display
Enclosure	NEMA12
Paint Color	Magnum Systems Blue - RAL 5015
Bagger Overall Dimensions	L 26-35/64" x W 15-7/32" x H 29"
Shipping Weight	160 lbs
Crate Dimensions	L 22"x W 37"x H 35"

DIMENSIONS:

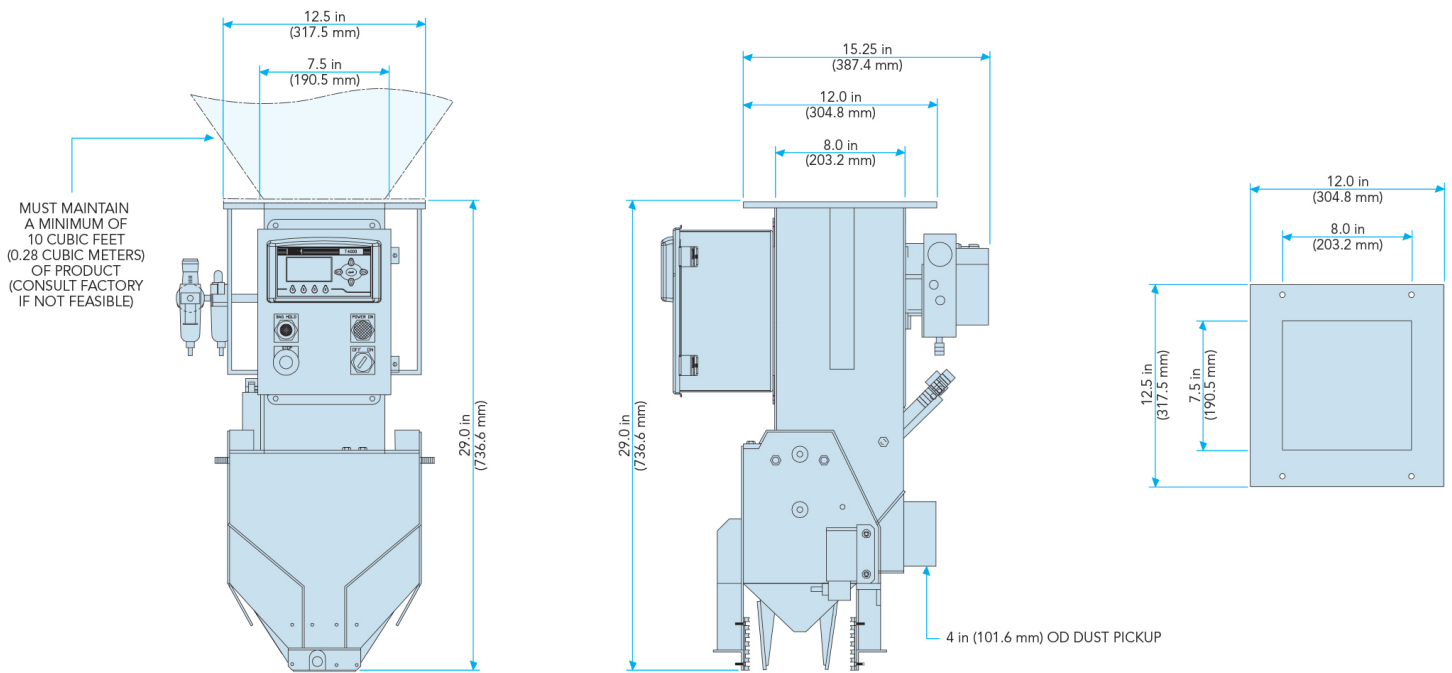

Diagram dimensions are for reference only*