

Impact Huller VSH-2096

IMPACT HULLER

The VSH-2096 is designed to hull products such as oats, sunflower seeds, spelt, hemp, barley, buckwheat, canary seed, cocoa beans, etc. by passing these materials through a rotating impeller and propelling them into the surrounding impact ring. This dynamically balanced, hardened impeller contains a series of grooved vanes which force individual kernels to orient themselves for maximum hulling efficiency at impact. The impeller can be programmed for the precise speed desired using the variable frequency drive.

The impact ring is available in various types of materials, most commonly stone, ceramic and polymer, depending on the application. Each impact ring can be vertically adjusted to allow for better performance and to promote even wear, resulting in an extended service life. The support legs of the VSH-2096 can be positioned upside-down to suspend the huller from the ceiling.



IMPACT HULLER VSH-2096

- **FLEXIBLE** - The VSH-2096 is designed to hull a wide variety of products including oats, sunflower seeds, spelt, hemp, barley, buckwheat, canary seed, cocoa beans, and other products.
- **ADJUSTABLE** - The VSH-2096's Impeller speed can be precisely adjusted using the variable frequency inverter. The Impact ring is available in various materials to best match your specific hulling requirements.
- **STURDY** - A heavy, welded steel housing helps provide long-term smooth operation.
- **LOW MAINTENANCE** - Containing just two wearing parts and one moving part means the VSH-2096 is nearly maintenance-free.

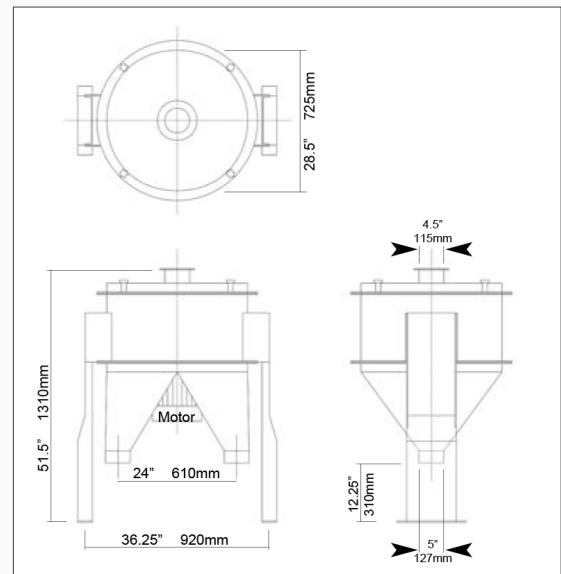

SPECIFICATIONS:

- **WEIGHT:** 550 Lbs (250 Kg) Net weight, including motor
- **DRIVE OPTIONS:** 7.5hp -1800rpm or 5hp - 1200rpm direct drive motor
- **ASPIRATION REQUIREMENTS:** Approx. 400cfm (12m³/min) of air at the outlet

CAPACITY:

When hulling Oats, the capacity of the VSH-2096 is approximately 4500 Lbs/hr (2000 Kg/hr)