

### RAD CHAIN CONVEYORS MODELS

RAD chain conveyors are high performance systems for moving your crops efficiently. We offer conveyors for all applications including; Inclined Receiving Conveyors, Round Bottom Conveyors, Double-Run Conveyors, En-Masse Conveyors and Low Profile Silo Conveyors .

### BUILT TO LAST

RAD conveyors are heavy duty Galvanized construction offers with optional liners in Hardox or UHMW. All conveyors are industrial design to increased strength & durability.

### MULTIPLE FEATURES

RAD conveyors offer many features to maximize your performance to reduce operation costs. High Quality bearings, Hardened teeth sprockets, Nylon paddles, Heavy duty Takes-up, HD chain, larger attachments plates, Stainless steel return rails, TGP 1045 shafts are only some of the standard features of our conveyors.

## RAD Flat Bottom, Incline Drag Conveyor



### STANDARD FEATURES:

- High performance conveyor made of corrosion-resistant galvanized steel
- UHMW polyethylene paddles resist wear
- Incline conveyor lids grain up to 45 degrees thanks to an anti-return device (plenum)
- Optional liner for extension bottom and sides
- Solid and durable construction
- Highly resistant stainless steel return rail
- Ultratene paddle for optimal cleaning of the conveyor bottom
- Pre-assembled drive, head and tail to facilitate installation
- 600 to 15,000 bushels per hour
- Easy to install and little maintenance required
- Wide range of choices to match your project

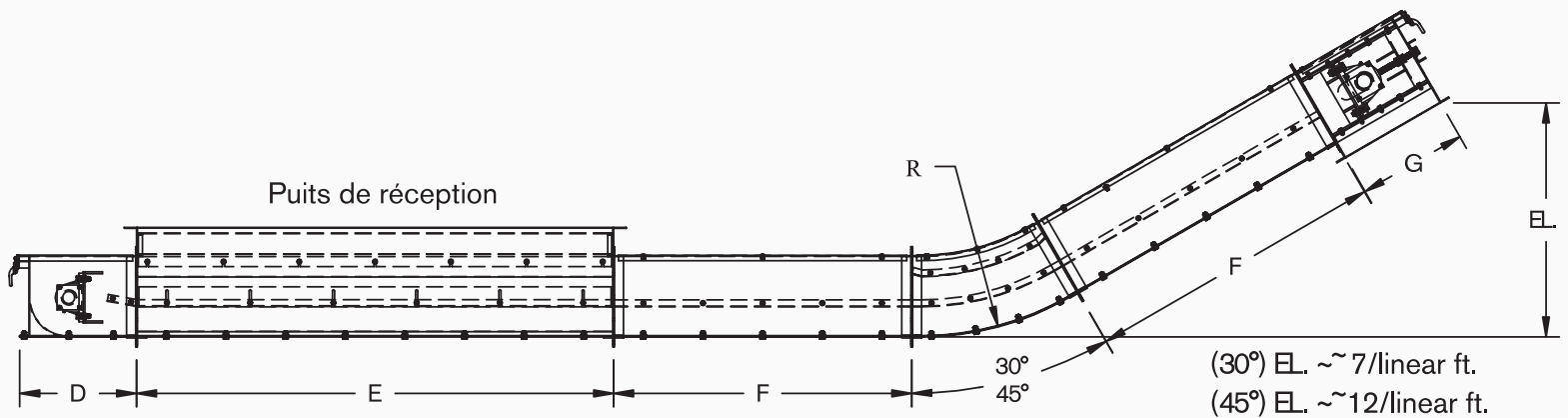

MODEL	A	B	C	D	E	F	G	H	J	K	L	R
9" X 12"	9"	12"	15 1/8"	17 5/8"	8'	5'-10'	26"	24"	18"	9"	1 1/2"	60"
14" X 16"	14"	16"	20 1/8"	23 1/2"	8'	5'-10'	28"	36"	24"	14"	1 1/2"	60"
18" X 16"	18"	16"	20 1/8"	22 1/8"	8'	5'-10'	28"	36"	25"	18"	1 1/2"	60"
20" X 20"	20"	20"	24 1/8"	27 1/2"	8'	5'-10'	36"	42"	30"	20"	1 1/2"	66"
24" X 20"	24"	20"	24 1/8"	28"	8'	5'-10'	36"	42"	32"	24"	1 1/2"	66"
26" X 26"	26"	26"	30 1/8"	1 1/2"	8'	5'-10'	38"	42"	38 1/2"	26"	1 1/2"	66"

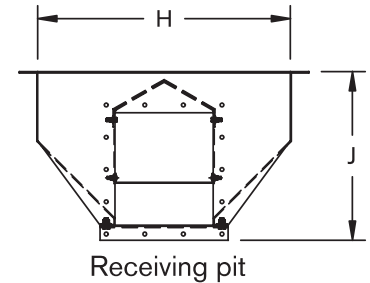

	9" X 12"	14" X 16"	18" X 16"	20" X 20"	24" X 20"	26" X 26"
Tail	10 ga	10 ga	10 ga	10 ga	10 ga	10 ga
Direct inlet	12 ga	10 ga	10 ga	10 ga	10 ga	10 ga
Section	10 ga	10 ga	10 ga	10 ga	10 ga	10 ga
Head	10 ga	10 ga	10 ga	10 ga	10 ga	10 ga
Cover	14 ga	14 ga	14 ga	12 ga	12 ga	12 ga
Trough bottom	10 ga	10 ga	10 ga	8 ga	8 ga	8 ga
Receiving pit	10 ga	10 ga	10 ga	10 ga	10 ga	10 ga
Chain	81X	81X or 81XH	81XH	81XH	(2) 81XH	(2) 81XH
Chain sprocket	8 teeth	12 teeth	12 teeth	14 teeth	14 teeth	19 teeth
Paddle thickness	1/2"	1/2"	1/2"	1/2"	1/2"	1/2"

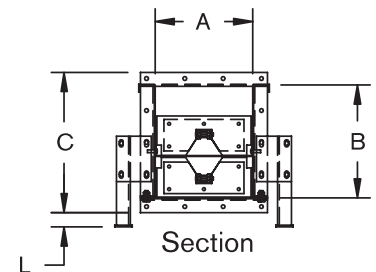

	RPM	BHP	FT <sup>3</sup> /HR
9" x 12" @ 52 ft./min.	29	600	750
9" x 12" @ 78 ft./min.	44	900	1125
9" x 12" @ 104 ft./min.	58	1200	1500
9" x 12" @ 130 ft./min.	73	1500	1875
9" x 12" @ 208 ft./min.	117	2400	3000
14" x 16" @ 102 ft./min.	38	2400	3000
14" x 16" @ 127 ft./min.	48	3000	3750
14" x 16" @ 148 ft./min.	56	3500	4375
14" x 16" @ 169 ft./min.	64	4000	5000
18" x 16" @ 132 ft./min.	50	4000	5000
18" x 16" @ 164 ft./min.	62	5000	6250
18" x 16" @ 197 ft./min.	75	6000	7500
20" x 20" @ 132 ft./min.	43	6000	7500
20" x 20" @ 154 ft./min.	50	7000	8750
20" x 20" @ 176 ft./min.	57	8000	10000
24" x 20" @ 132 ft./min.	43	7000	8750
24" x 20" @ 151 ft./min.	49	8000	10000
24" x 20" @ 189 ft./min.	62	10000	12500
26" x 20" @ 128 ft./min.	33	10000	12500
26" x 20" @ 154 ft./min.	39	12000	15000
26" x 20" @ 192 ft./min.	49	15000	18700

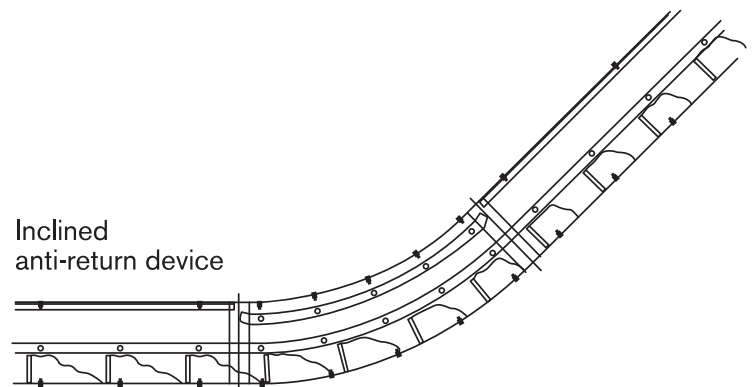
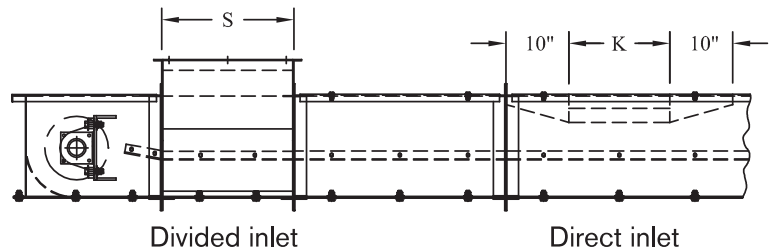

The capacities shown are for conveyors with a maximum incline of 15° transporting free-flowing dry material at 45 lb./cu. ft. or 56 lb./bu. Capacities may vary based on the conveyor's degree of inclination and the material being transported.

All conveyors are made of galvanized steel or painted steel. • Other gauges available.