

RAD CHAIN CONVEYORS MODELS

RAD chain conveyors are high performance systems for moving your crops efficiently. We offer conveyors for all applications including; Inclined Receiving Conveyors, Round Bottom Conveyors, Double-Run Conveyors, En-Masse Conveyors and Low Profile Silo Conveyors .

BUILT TO LAST

RAD conveyors are heavy duty Galvanized construction offers with optional liners in Hardox or UHMW. All conveyors are industrial design to increased strength & durability.

MULTIPLE FEATURES

RAD conveyors offer many features to maximize your performance to reduce operation costs. High Quality bearings, Hardened teeth sprockets, Nylon paddles, Heavy duty Takes-up, HD chain, larger attachments plates, Stainless steel return rails, TGP 1045 shafts are only some of the standard features of our conveyors.

RAD Flat Bottom, Incline Drag En-Masse Conveyor

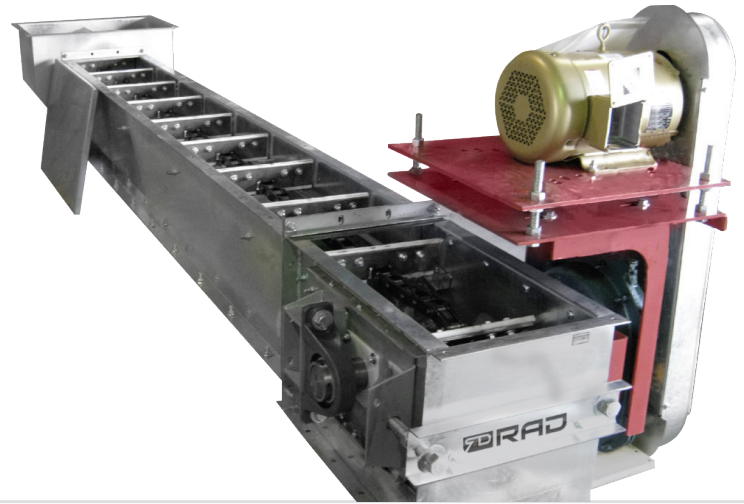

MOVE HIGH VOLUMES OF BULK MATERIAL EVENLY AND EFFICIENTLY WITH THE EN- MASSE DRAG CONVEYOR:

- High performance extra heavy-duty galvanized construction built to last
- 1500 to 15,000 bushels/hour
- Tall section 8-10 ga frame with heavy duty A.R Steel bottom plate (1/8" - 3/16") standard
- Trough section 8-10ga bottom and sides standard
- Abrasion resistant A.R sttel (Domex) bolted wear plate available on Trough section and receiving hopper
- Head section 8-10ga housing with heavy duty chain tension take-up system
- Durable cast iron steel sprockets. split sprocket available

- Heavy duty pillow block Dodge bearings with turned ground and polished shaft. Split bearing available.
- Dust and weather tight, maintenance friendly
- High resistant 12ga type 304 stainless sttel return rail
- The smaller paddle, featured on en-masse models, enables a higher capacity
- Each UHMW paddle is bolted to a formed steel backer plate welded onto the chain
- 81X and 81XH roller elded chain is engineered for durability, reliability, and longevity. Solid bushing, solid roller and quad staked riveting
- Dodge belt speed gear reducer standard and motorized direct drive torque-arm reducer available.

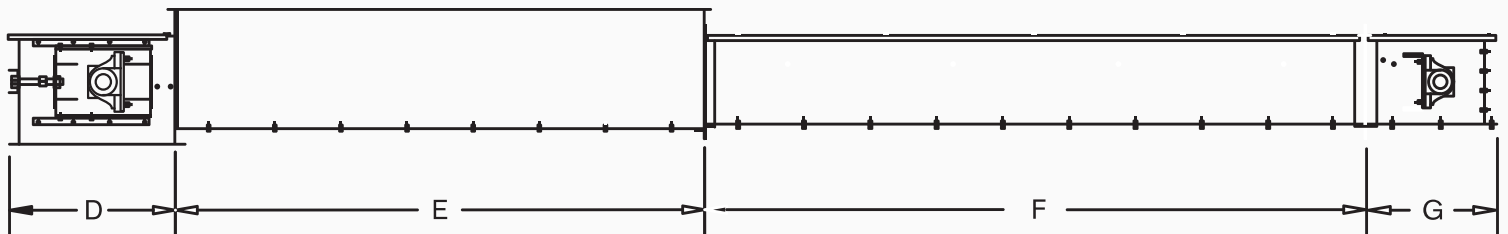

DIMENSIONS:

MODEL	A	B	C	D	E	F	G	H	J
9" X 12"	9"	12"	15 1/8"	17 5/8"	96"	5'-10'	26"	24"	18"
14" X 16"	14"	16"	20 1/8"	23 1/2"	96"	5'-10'	28"	30"	24"
18" X 16"	18"	16"	20 1/8"	23 9/16"	96"	5'-10'	28"	36"	25"
20" X 20"	20"	20"	24 1/8"	27 1/2"	96"	5'-10'	36"	36"	30"

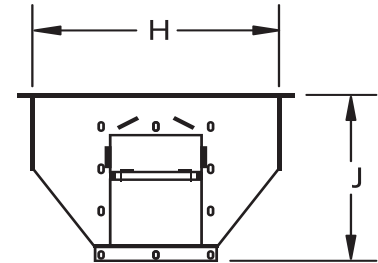

SPECIFICATIONS:

	9" X 12"	14" X 16"	18" X 16"	20" X 20"
Tail	10ga	10ga	10ga	10ga
Direct inlet	10ga	10ga	10ga	10ga
Trough sides	10ga	10ga	10ga	10ga
Trough bottom	10ga	10ga	10ga	8ga
Head	10ga	10ga	10ga	8ga
Receiving hopper	10ga	10ga	10ga	10ga
Chain	81X	81X or 81XH	81X or 81XH	81X or 81XH
Chain sprocket	8 teeth	12 teeth	12 teeth	14 teeth
Paddle thickness	1/2"	1/2"	1/2"	1/2"

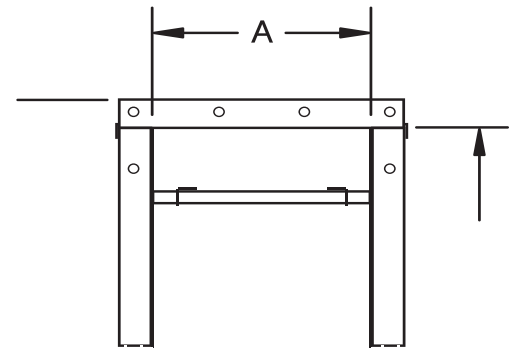

CAPACITY BUSHELS / HOUR:

	RPM	BU/HR	FT ³ /HR
9" x 12" @ 61 ft/min	35	1500	1866
9" x 12" @ 98 ft/min	56	2400	2986
9" x 12" @ 123 ft/min	69	3000	3733
9" x 12" @ 143 ft/min	81	3500	4355
9" x 12" @ 164 ft/min	92	4000	4978
14" x 16" @ 99 ft/min	38	5000	6222
14" x 16" @ 119 ft/min	45	6000	7467
14" x 16" @ 138 ft/min	53	7000	8711
14" x 16" @ 158 ft/min	60	8000	9956
18" x 16" @ 121 ft/min	46	8000	9956
18" x 16" @ 151 ft/min	57	10000	12445
20" x 20" @ 100 ft/min	24	10000	12445
20" x 20" @ 120 ft/min	30	12000	14934
20" x 20" @ 150 ft/min	36	15000	18668

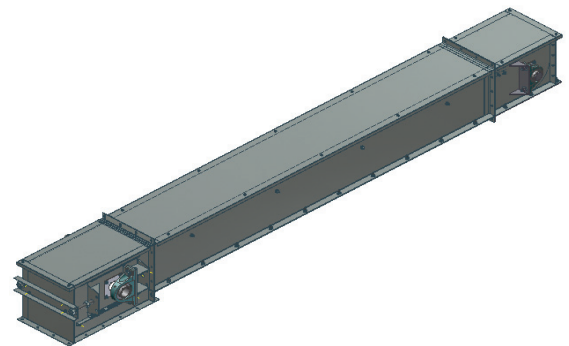

The capacities shown are for horizontal conveyors transporting free-flowing dry material at 45lb./cu or 56lb./bu. Maximum inclination for En-masse conveyor is 14 degrees. Capacities may vary based on the conveyor's degree of inclination and the material being transported.

All conveyors are made of galvanized steel or painted steel available.